

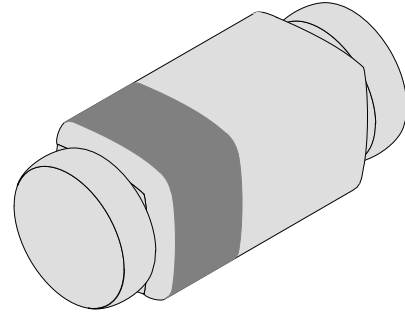

## Fast Switching Diode

### Features

- Silicon Epitaxial Planar Diodes
- Electrical data identical with the devices 1N4148 and 1N4448 respectively
- Quadro Melf package



96 12009

### Applications

- Extreme fast switches

### Order Instruction

Type	Type Differentiation	Ordering Code	Remarks
LS4148	$V_{RRM} = 100\text{ V}$ , $V_F @ I_F 50\text{mA} = 1\text{ V}$	LS4148-GS08	Tape and Reel
LS4448	$V_{RRM} = 100\text{ V}$ , $V_F @ I_F 100\text{mA} = 1\text{ V}$	LS4448-GS08	Tape and Reel

### Absolute Maximum Ratings

$T_j = 25^\circ\text{C}$

Parameter	Test Conditions	Type	Symbol	Value	Unit
Repetitive peak reverse voltage			$V_{RRM}$	100	V
Reverse voltage			$V_R$	75	V
Peak forward surge current	$t_p = 1\mu\text{s}$		$I_{FSM}$	2	A
Repetitive peak forward current			$I_{FRM}$	500	mA
Forward current			$I_F$	300	mA
Average forward current	$V_R = 0$		$I_{FAV}$	150	mA
Power dissipation			$P_V$	500	mW
Junction temperature			$T_j$	175	$^\circ\text{C}$
Storage temperature range			$T_{stg}$	-65...+175	$^\circ\text{C}$

### Maximum Thermal Resistance

$T_j = 25^\circ\text{C}$

Parameter	Test Conditions	Symbol	Value	Unit
Junction ambient	on PC board 50 mm x 50 mm x 1.6 mm	$R_{thJA}$	500	K/W

### Electrical Characteristics

$T_j = 25^\circ\text{C}$

Parameter	Test Conditions	Type	Symbol	Min.	Typ.	Max.	Unit
Forward voltage	$I_F=5\text{ mA}$	LS4448	$V_F$	0.62		0.72	V
	$I_F=50\text{ mA}$	LS4148	$V_F$		0.86	1	V
	$I_F=100\text{ mA}$	LS4448	$V_F$		0.93	1	V
Reverse current	$V_R=20\text{ V}$		$I_R$			25	nA
	$V_R=20\text{ V}, T_j=150^\circ\text{C}$		$I_R$			50	$\mu\text{A}$
	$V_R=75\text{ V}$		$I_R$			5	$\mu\text{A}$
Breakdown voltage	$I_R=100\text{ }\mu\text{A}, t_p/T=0.01, t_p=0.3\text{ ms}$		$V_{(BR)}$	100			V
Diode capacitance	$V_R=0, f=1\text{ MHz}, V_{HF}=50\text{ mV}$		$C_D$			4	pF
Rectification efficiency	$V_{HF}=2\text{ V}, f=100\text{ MHz}$		$\eta_r$	45			%
Reverse recovery time	$I_F=I_R=10\text{ mA}, i_R=1\text{ mA}$		$t_{rr}$			8	ns
	$I_F=10\text{ mA}, V_R=6\text{ V}, i_R=0.1 \times I_R, R_L=100\text{ }\Omega$		$t_{rr}$			4	ns

### Characteristics ( $T_j = 25^\circ\text{C}$ , unless otherwise specified)

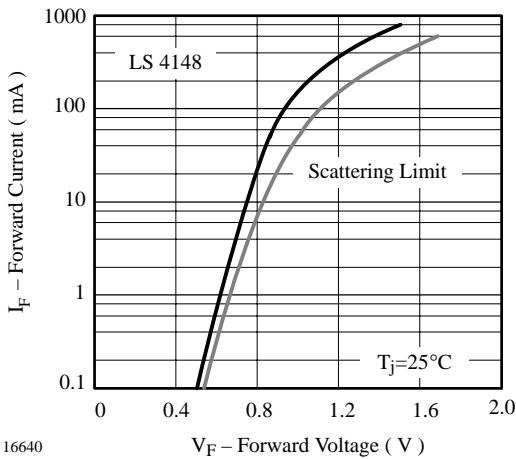

Figure 1. Forward Current vs. Forward Voltage

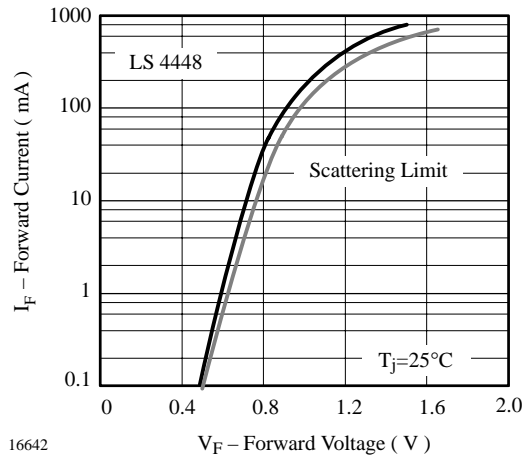
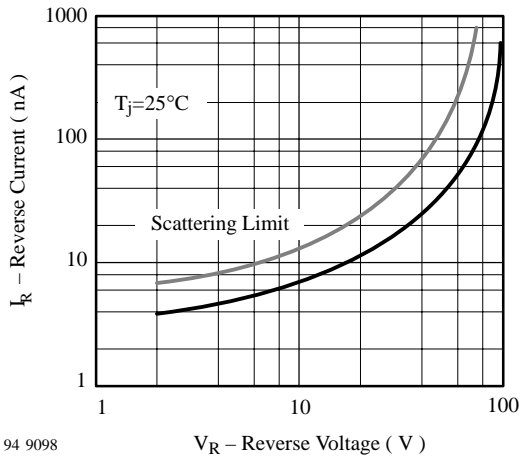
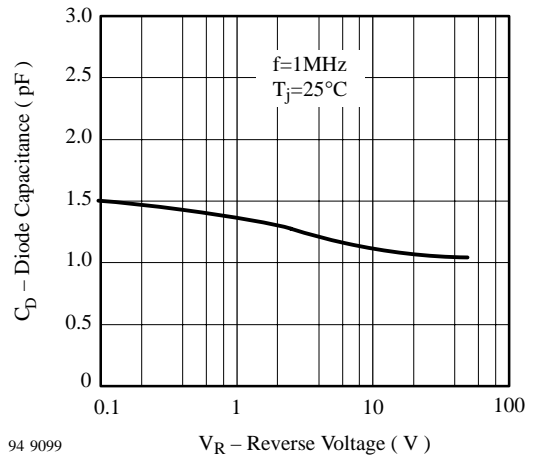

Figure 2. Forward Current vs. Forward Voltage



94 9098

Figure 3. Reverse Current vs. Reverse Voltage



94 9099

Figure 4. Diode Capacitance vs. Reverse Voltage

**Dimensions in mm**

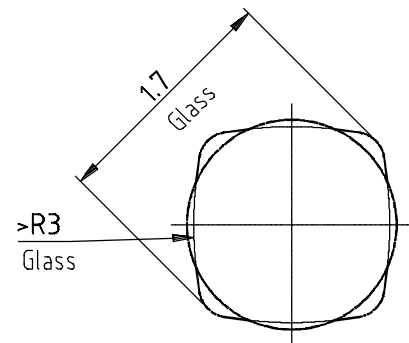
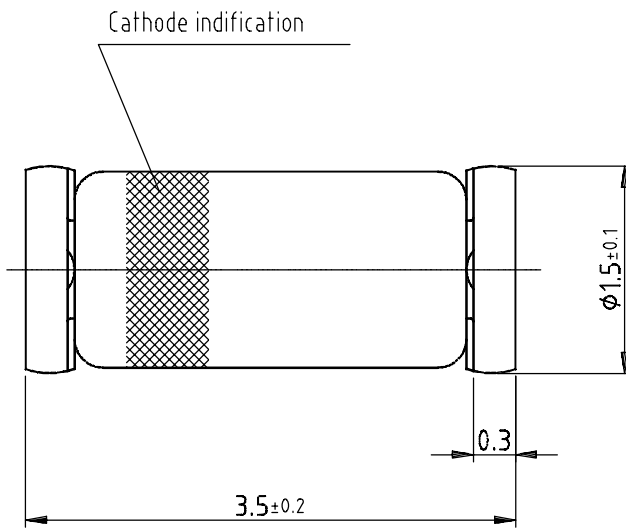

Glass case  
 Quadro MELF / SOD80  
 similar to JEDEC 213 AA

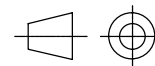

96 12071

technical drawings  
 according to DIN  
 specifications



### Ozone Depleting Substances Policy Statement

It is the policy of **Vishay Semiconductor GmbH** to

1. Meet all present and future national and international statutory requirements.
2. Regularly and continuously improve the performance of our products, processes, distribution and operating systems with respect to their impact on the health and safety of our employees and the public, as well as their impact on the environment.

It is particular concern to control or eliminate releases of those substances into the atmosphere which are known as ozone depleting substances (ODSs).

The Montreal Protocol (1987) and its London Amendments (1990) intend to severely restrict the use of ODSs and forbid their use within the next ten years. Various national and international initiatives are pressing for an earlier ban on these substances.

**Vishay Semiconductor GmbH** has been able to use its policy of continuous improvements to eliminate the use of ODSs listed in the following documents.

1. Annex A, B and list of transitional substances of the Montreal Protocol and the London Amendments respectively
2. Class I and II ozone depleting substances in the Clean Air Act Amendments of 1990 by the Environmental Protection Agency (EPA) in the USA
3. Council Decision 88/540/EEC and 91/690/EEC Annex A, B and C (transitional substances) respectively.

**Vishay Semiconductor GmbH** can certify that our semiconductors are not manufactured with ozone depleting substances and do not contain such substances.

**We reserve the right to make changes to improve technical design and may do so without further notice.**

Parameters can vary in different applications. All operating parameters must be validated for each customer application by the customer. Should the buyer use Vishay Semiconductors products for any unintended or unauthorized application, the buyer shall indemnify Vishay Semiconductors against all claims, costs, damages, and expenses, arising out of, directly or indirectly, any claim of personal damage, injury or death associated with such unintended or unauthorized use.

Vishay Semiconductor GmbH, P.O.B. 3535, D-74025 Heilbronn, Germany  
Telephone: 49 (0)7131 67 2831, Fax number: 49 (0)7131 67 2423

This datasheet has been download from:

[www.datasheetcatalog.com](http://www.datasheetcatalog.com)

Datasheets for electronics components.